

深圳市精钻智能制造有限公司

地址 深圳市光明区马田街道石围社区石围大田洋工业区1号A栋101

电话: 86-755-27296210 27296211 27296212

传真: 86-755-27296213

Q Q: 2850995008

全国服务热线: 400-880-9912

ShenZhen JingZuan Intelligent Manufacturing CO.,LTD

Add:No.101, Building A, Shiwei Datianyang Industrial Area, Matian Ave, Guangming Area, Shenzhen

TEL: 86-755-27296210 27296211 27296212

FAX: 86-755-27296213

Q Q: 2850995008

Hotline: +86 400-880-9912

苏州市精钻智能制造有限公司

SuZhou Jingzuan Intelligent Manufacturing Co.,LTD

苏州市相城区望亭镇何家村杭桥路3号

ADD:No.3, Hangqiao Road, Hejiajiao Village, Wangting Town, Xiangcheng Area, Suzhou

电话 (TEL) : 0512-6575 1221

传真 (FAX) : 0512-6575 1222



Folio: 210*285mm 1/16
Revision: 2019-5 first printing
Printing: 2-5000
Code: SZJZ-3A 01-46
[Http://www.szjztools.com](http://www.szjztools.com)
[Https://szjztools.1688.com](https://szjztools.1688.com)
[Https://szjztools.en.alibaba.com](https://szjztools.en.alibaba.com)

Hotline: 400-880-9912

本画册最终解释权归本公司所有, 文中图片及文字仅供参考, 产品以实物为准, 如有变更, 恕不另行通知, 详情请致电 0755-27296210

Final interpretation of all contents, text in the pictures and text are for reference only, actual product, Subject to change without notice, Please call +86 755 27296210.

版权所有 翻版必究

倾力打造夹具一站式服务平台

Efforts to create a one-stop service platform for fixtures

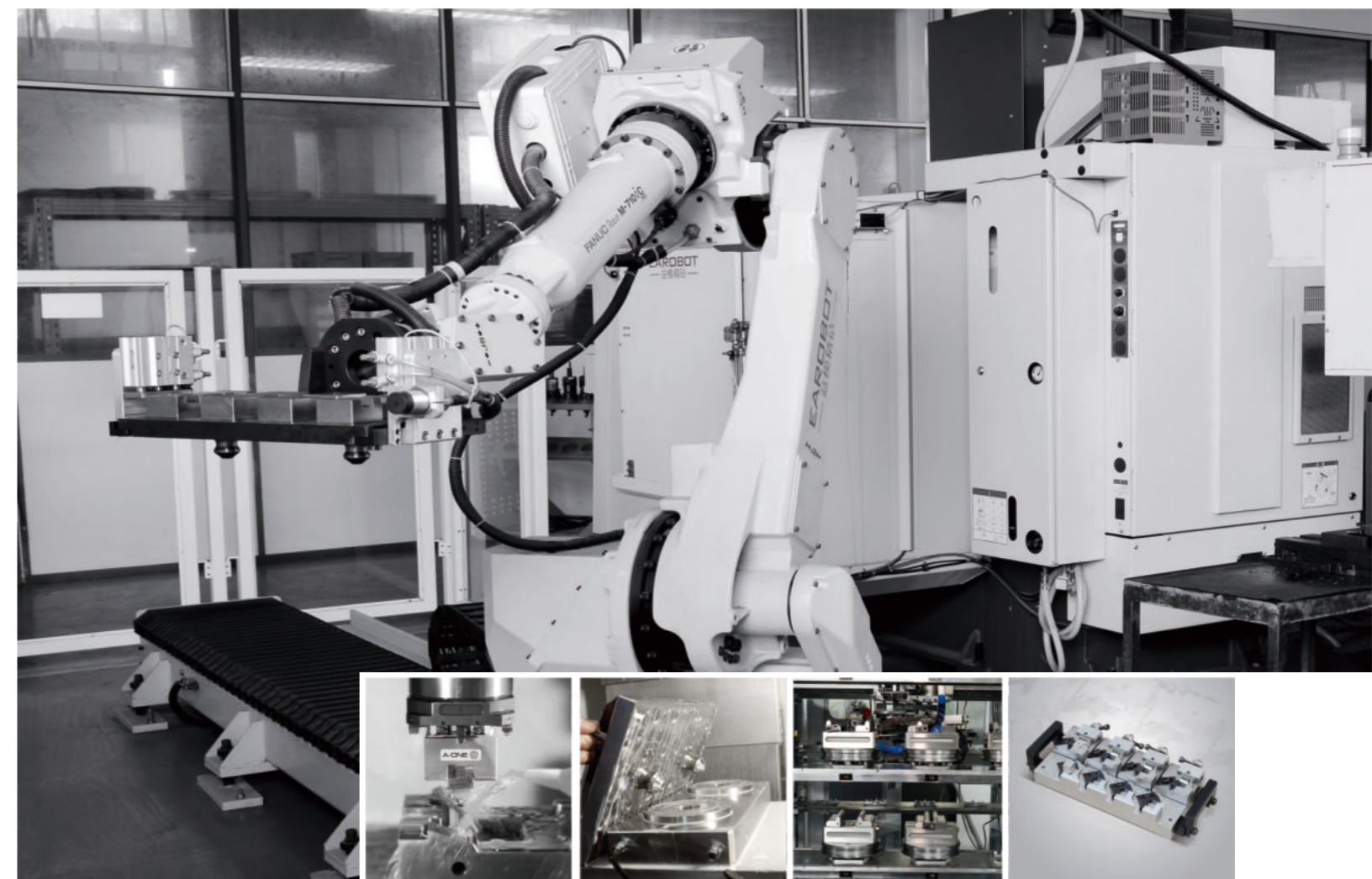

公司简介

COMPANY
PROFILE

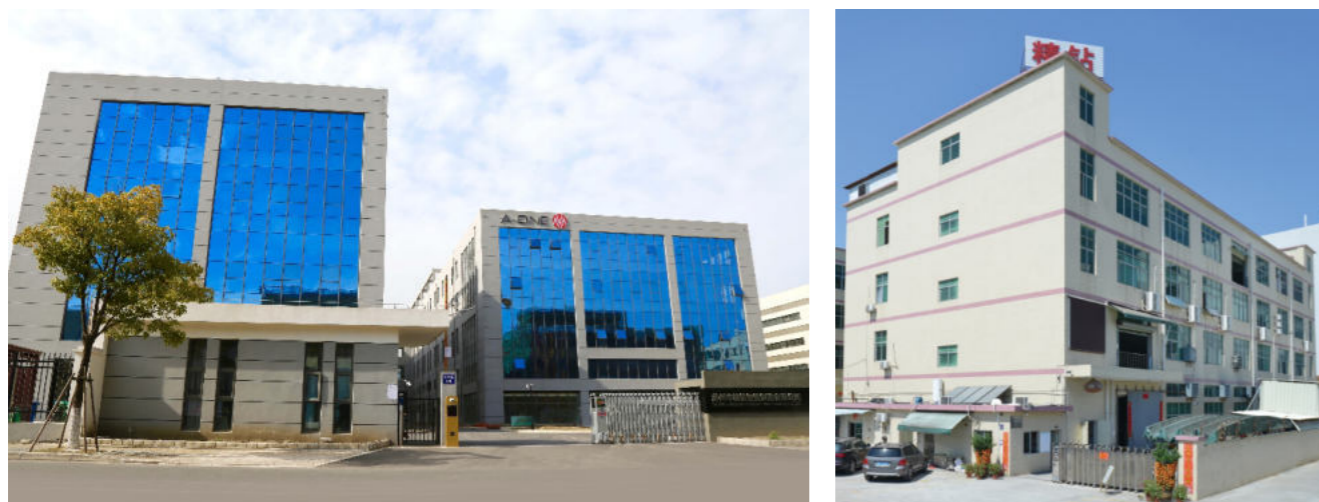

深圳市精钻智能制造有限公司自2000年成立以来，秉承“精益求精，钻石服务”的经营理念，不断引进先进的设备及技术，生产高品质、稳定可靠的产品，为客户创造更多价值。现有牧野（MAKINO）、哈斯（HAAS）数控加工中心；奥柯玛（OKUMA）数控车床，琼格（JUNG）数控成型磨床、克林伯格（KELLENBERGER-100）数控内外圆磨床、摩尔（MOORE）坐标磨床及蔡司（ZEISS）三次元等先进的制造设备及检测仪器，经过20年多年的技术沉淀及经验积累，已发展成具有一定规模的生产企业。

公司主要生产：零点快换夹具系列；电极制造夹具系列；自定心虎钳及燕尾槽夹具系列；夹头、导套等轴类产品系列，广泛应用于模具电极制造和零件加工领域，适用于加工中心、数控车床、电火花机、线切割等设备，凭借产品丰富、品质稳定、价格合理，赢得客户的信赖与支持，产品远销美国、俄罗斯、德国、瑞士、意大利、法国、西班牙、以色列、日本、韩国等国家。

精钻公司于2016年与武汉益模科技股份有限公司合资成立益模精钻机器人有限公司，致力于为客户提供自动化上下料整体解决方案。

并于2019年苏州生产基地正式开工建设，使用面积达25000平方米，为高品质、批量化生产提供强有力保证，并承接非标夹具设计、精密零件及OEM委托制造服务，助您开创事业新版图。

精钻公司始终坚持：为企业及行业发展有所贡献而奋斗，我们以此为目标，专注行业发展，洞察客户需求，统合综效，以双赢思维服务好每一位客户。

精钻公司始终坚持：为企业及行业发展有所贡献而奋斗，我们以此为目标，专注行业发展，洞察客户需求，统合综效，以双赢思维服务好每一位客户。

Since its establishment in 2000, Shenzhen Jingzuan Intelligent Manufacturing Co., Ltd. has been adhering to the business philosophy of "Keep Improving, Diamond Service", constantly introducing advanced equipment and technology, producing high-quality, stable and reliable products, and creating more value for customers. The company currently has MAKINO and HAAS CNC machining centers; OKUMA CNC lathes, JUNG CNC forming grinders, KELLENBERGER-100 CNC internal and external cylindrical grinders, MOORE coordinate grinder, ZEISS three-dimensional, other advanced manufacturing equipment and testing instruments. After more than 20 years of technical precipitation and experience accumulation, it has developed into a certain scale of production enterprises.

The company mainly produces: zero-point quick change fixture series; electrode manufacturing fixture series; self-centering vise and dovetail fixture series; shaft product series such as collet chuck and guide sleeves, which are widely used in the field of mold electrode manufacturing and parts processing, suitable for machining centers, CNC lathes, EDM machines, wire cutting and other equipment. With rich products, stable quality and reasonable prices, it has won the trust and support of customers. The products are exported to the United States, Russia, Germany, Switzerland, Italy, France, Spain, Israel, Japan, South Korea and other countries.

In 2016, Jingzuan Company and Wuhan Eman Technology Co., Ltd. jointly established Eman&Aone Robot Tech Co.,Ltd., dedicated to providing customers with overall solutions for automated loading and unloading.

In 2019, the Suzhou production base officially started construction, with an area of 25,000 square meters, providing a strong guarantee for high-quality, mass production, and undertaking non-standard fixture design, precision parts and OEM commissioned manufacturing services to help you create a new business map.

Jingzuan Company always insists: strive to contribute to the development of the enterprise and the industry. We take this as the goal, focus on industry development, insight into customer needs, integrate comprehensive results, and serve every customer with a win-win thinking.

发展历程

DEVELOPMENT PATH



2000年6月创立精钻五金行，精钻名称来源：精益求精，钻石服务，次年迁往深圳福永。

At June of year 2000, we founded Jingzuan hardware store, the name of Jingzuan meaning: Seek for greater perfection , to offer diamond service. The next year move to Fuyong, Shenzhen

2000年

开设工厂，成立深圳市精钻五金厂，购置第一台台湾数控车床及其他设备，专业加工精密零件。

Established a factory and established Shenzhen Fine Diamond Hardware Factory to purchase the first Taiwanese CNC lathes and other equipment to professionally process precision parts.

2002年

乔迁新厂，购置多台数控车床及精密内外圆磨床,生产数控车床夹头、导套。

In the year of 2004, We moved to a new factory, purchased a number of CNC lathes and precision internal and external circular grinding machine, which to produce numerical control machine collet chuck and guide bush.

2004年

设立分公司：精创夹具，为客户提供高精度夹具解决方案，同年新工厂迁往深圳沙井。

We Set up a branch company- JingChuang JIG in 2007 , provide high precision fixture solution to customer. then we moved new factory to Shajing, also in Shenzhen

2007年

2009年

更名：深圳市精钻精密五金工具有限公司，全面推行 ISO9001:2008国际质量管理体系认证，开发多款快速定位夹具，并取得专利证书。

We are changed name to Shenzhen Jingzuan Precision Hardware & Tools Co. Ltd, and fully implemented ISO9001:2008 international quality management system.

2016年

正式获得国家高新企业认证，并与武汉益模科技股份有限公司合资成立益模精钻机器人有限公司，致力于为客户提供夹具及自动化整体的解决方案。

We obtained national high-tech enterprise certification and joint venture with WuHan EMan Software Technology Co., Ltd.

2017年

为扩大生产规模，我司乔迁新厂至光明新区，并从国外引进自动化生产线，全面提升企业综合竞争力，为客户创造新价值，我们一直在路上。

To expand production scale, we moved new factory to GuangMing new area, Imported automatic production line from abroad, comprehensively enhance the competitiveness of enterprises, provide quality service, we are on the way and never stop!

2019年

产能提升，从华南辐射全国。在苏州新建产业园，引进进口瑞士KELLENBERGER 100—完美的数控万能内外圆磨床、进口高精度数控平面成型磨床，进一步贴合客户，品质、服务再次提升，助力中国智能制造

Increased production capacity, radiating from the south to the entire country, building a new industrial park in Suzhou, introducing imported Switzerland KELLENBERGER 100-perfect CNC universal inner and outer cylindrical grinding machine, importing high precision profile and surface CNC grinding machine, further fitting customers, improving quality and service again, making contributions to China's intelligent manufacturing.

卓越的团队
Excellent team

专注生产制造夹具近20年，拥有卓越的研发、生产、销售服务团队，获得多项技术专利；先进的管理，完整的生产线为迅速交货提供了可靠的保障。

A-one concentrated on manufacturing fixture for nearly 20 years . we have an excellent R&D, production and service team, which has acquired many patents. The advanced management and whole production line assure the quick delivery.



A-ONE 

先进的理念
Innovative concept

作为夹持和抓取系统生力军，A-ONE公司在精密夹具领域和自动化抓取系统上不断进取，近20年专注研发生产。A-ONE公司坚持以高效，精确，和可靠的理念赢得客户信赖。

As the fresh force of clamping and holding system, A-one company has been processing in the precision clamping and automation gripping system field since After nearly 20 years, A-one company insist on the concept of "efficient, precision, reliable" to win the customers' trust.



企业文化
ENTERPRISE
CULTURE

企业精神
Enterprise spirit

激情、创新、诚信、敬业
Passion, innovation, integrity, dedication



公司愿景

Company vision

使精钻公司成为一家具有创新精神、员工引以自豪、合作伙伴长期信赖的企业。

To make a enterprise that's innovative, employees to take pride in the company and trusted by partners.



企业目标

Company goal

倾力打造夹具一站式服务平台
Efforts to create a one-stop service platform for fixtures

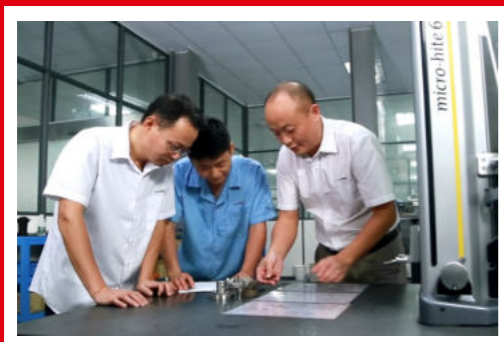

核心价值观

Key values

以人为本、成就客户、精益求精、钻石服务
People-oriented, delight customer, keep improving, diamond services.

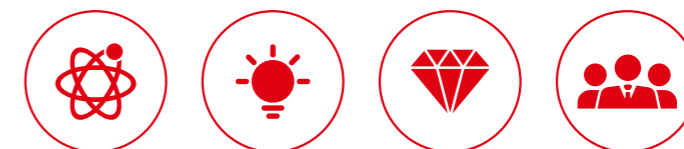

资质证书

**DQUALIFICATION
CERTIFICATE**

- ISO9001:2008质量管理体系
- CE认证
- 高新技术企业
- 中国制造网 认证供应商
- 东莞市数控刀具行业协会会员单位
- 深圳机械行业协会会员
- 中国制造之美五金类大奖
- ISO9001:2008 Quality Management System
- CE certification
- High-tech enterprises
- China Manufacturing Network Certified Supplier
- Dongguan CNC Tool Industry Association member
- Shenzhen Machinery Industry Association
- Made-in-China Hardware Category Award



倾力打造世界级夹具企业

**WE BUILDS THE
WORLD-CLASS
FIXTURE COMPANY**



专业 可靠 耐用 精密
 professional reliable durable precision

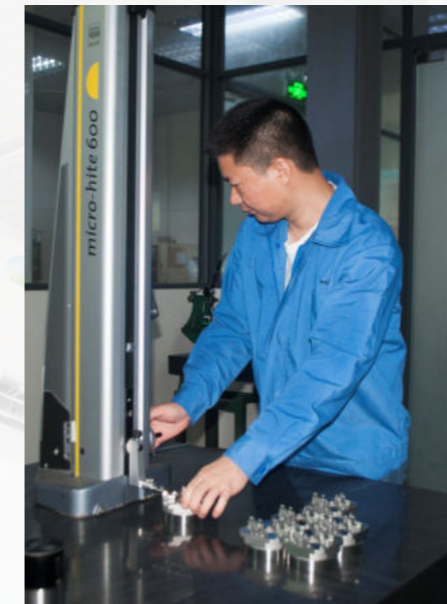

瑞士TESA测高仪
 Swiss TESA height indicator



瑞士TESA测高仪
 Swiss TESA height indicator

优良的品质保证 Excellent quality

公司全面推行ISO90001质量管理体系，并拥有德国ZEISS三坐标测量仪，ZEISS工具显微镜等检测设备，所有产品全检出货，为生产高精度的产品提供了强有力的保证。

We carried out the ISO90001 quality management system. The ZEISS coordinate measuring machine, ZEISS tool microscope and other advanced measuring equipment. All products are fully inspected to ensure the high precision.



ZEISS三坐标测量仪检测
 3A-110004零点卡盘
 ZEISS coordinate measuring machine detects Zero Point Chuck 3A-110004



ZEISS三坐标测量仪检测
 3A-200002旋转摆动式虎钳
 ZEISS coordinate measuring machine detects Rotatable Pendulum Vise 3A-200002



ZEISS三坐标测量仪检测
 ITS卡盘
 ZEISS coordinate measuring machine detects ITS Chuck



德国蔡司工具显微镜
 ZEISS tool microscope



万能工具显微镜
 ZEISS universal tool-measuring microscope



NIKON V-16A投影仪
 NIKON V-16A Projector



EASSON投影仪
 EASSON projector



洛氏硬度计
 Rockwell hardness

ZEISS三坐标测量仪
 ZEISS coordinate measuring machine

生产车间
**PRODUCTION
WORKSHOP**



MAKINO加工中心 MAKINO machining center



北京精雕精加工 Beijing JD CNC Precise machining



OKUMA 车床 OKUMA lathe

完整的、先进的生产加工设备、专职的技术人员及严格的生产工艺管控，保证了产品的交货期及配合客户应急的快速生产。

Complete, first-class processing equipment, professional technician and excellent manufacturing technique control, to ensure the product delivery and coordinate with emergency fasten manufacture as customer request.



OKUMA CNC 精加工 OKUMA CNC Precise machining

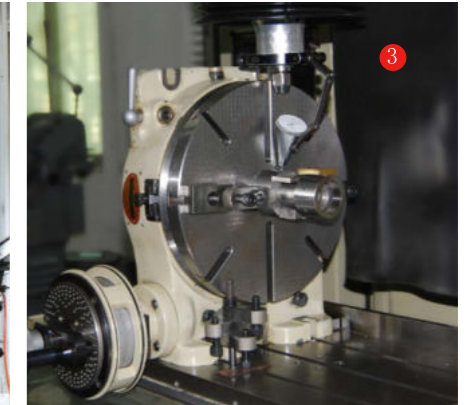
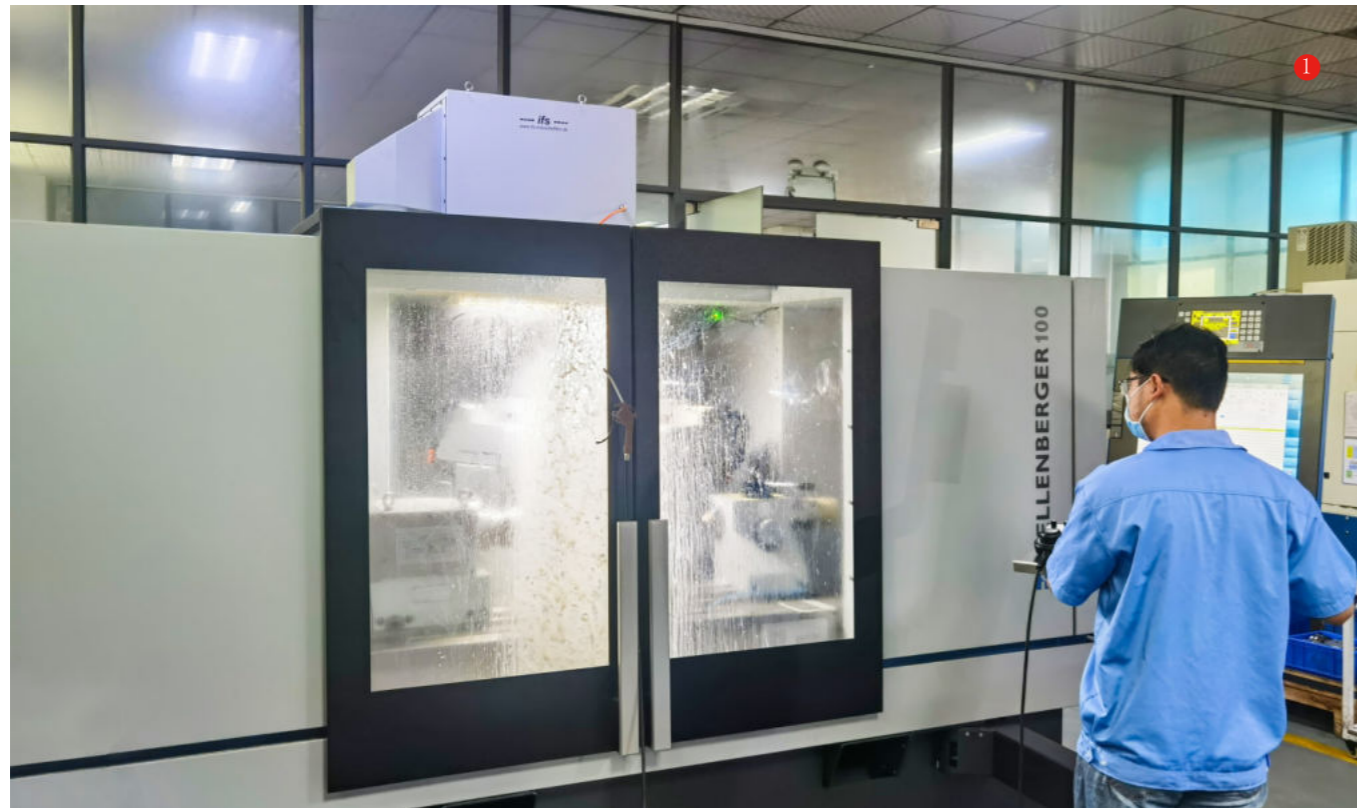

Manufacturing facilities 制造设备

完整的、一流的生产加工设备、专职的技术人员及优秀的生产工艺管控，保证了产品的交货期及配合客户应急的快速生产。

Complete, first-class processing equipment, professional technician and excellent manufacturing technique control, to ensure the product delivery and coordinate with emergency fasten manufacture as customer request.

- ① KELLENBERGER 100 — 完美的数控万能内外圆磨床
Perfect CNC universal inner and outer cylindrical grinding machine
 - 多达10种砂轮头架配置形式，所有砂轮头架均可进行直线或角向切入磨削。10 compact wheelhead options, all wheelheads as straight and/or angle approach
 - 适用于外圆、内孔和端面磨削。
For external/internal and face grinding
 - 控制系统的扩展软件，用于磨削标准非圆轮廓，例如：矩形、多边形、偏心圆、椭圆、半圆棒、扁平面等常见非圆轮廓。也用于磨削三棱形刀柄（COROMANT Capto），可进行圆周轮廓修正。
Software extension on machine control.
Simple program creation on machine control for grinding of standard non-circular contours such as Rectangle, Polygon, Eccentric, Ellipse, Rounded Bar, Flattening Subsequent Bar, Subsequent Square.
Forms for polygon toolholders (COROMANT CAPTO) including extensive correction possibilities.
- ② 斯图特精磨加工 STUDER precise grinding
- ③ MOORE 坐标磨车间 MOORE coordinate grinding workshop
- ④ 水磨加工 Water mill processing

工欲善其事，必先利其器

If a worker wants to do good, he must first sharpen his tools.



线切割加工 Wire cutting



OKAMOTO 平面磨加工 OKAMOTO flat grinding



先进的高精密设备配合完整的生产制造工艺，缩短产品生产周期，大大提升了产品质量和客户满意度。

The advanced high-precision equipment cooperates with the complete manufacturing process, shortens the product production cycle, and greatly enhances the product quality and customer satisfaction.

柔性自动化生产

Flexible Automated Production Workshop

自有的柔性生产线，可实现各种工件无人值守自动化加工，提升公司生产效率。

Its own flexible production line can realize unattended automatic processing of various workpieces and improve the company's production efficiency.

- 可以加工具有复杂型面的工件
- 加工精度高，质量稳定
- 生产效率高
- 有利于生产管理数字化
- Can process workpieces with complex profiles
- High precision machining and stable quality
- High productivity
- Facilitate the modernization of production management

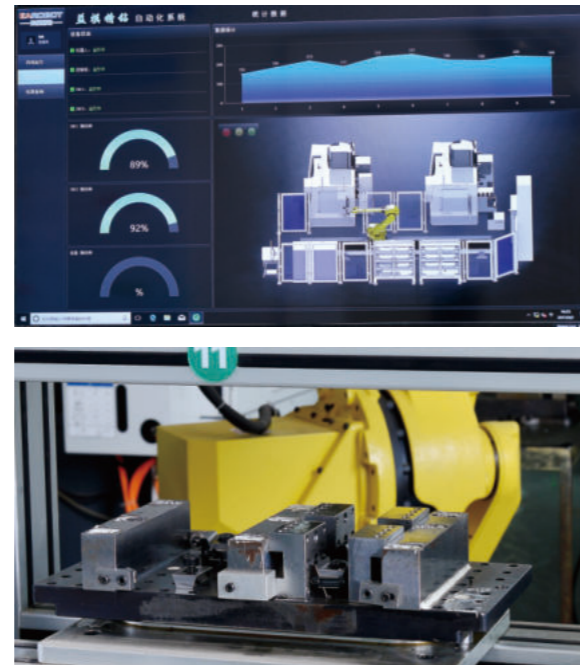

以工艺设计为先导，以数控技术为核心
Process design as a precursor, take cnc technology as the core





强大的仓储实力
Strong
 warehousing capacity

品类齐全的标准夹具仓储，
 可迅速完成订单。
 公司自有配送团队结合珠三角发达的物流，
 可及时安全的将货物送达给您。

A full range of standard fixtures storage,
 Orders can be completed quickly.
 The company's own distribution team combines
 The developed logistics in the Pearl River Delta.
 Safe and timely delivery of the goods to you.



快 Fast

秒速装夹，快速的装夹方式取代传统的人工锁紧装夹，大量减少人工作业量及时间。
Clamping in seconds, the way of fast clamp instead of traditional manual lock clamp, greatly reduce manual work and save time.

准 Precision

唯一标准化接口，精确的重复定位。
Unique standard interface, precise repeatability.

省 Save

省去加工中的校正动作，适合多样化及特殊工件加工，实现机外随意预调及检测。
Save alignment of processing, suitable for variety and special workpiece machining, achieve free preset and detection outside.

3A 产品应用于模具电极加工

3A products applied to mold electrode processing

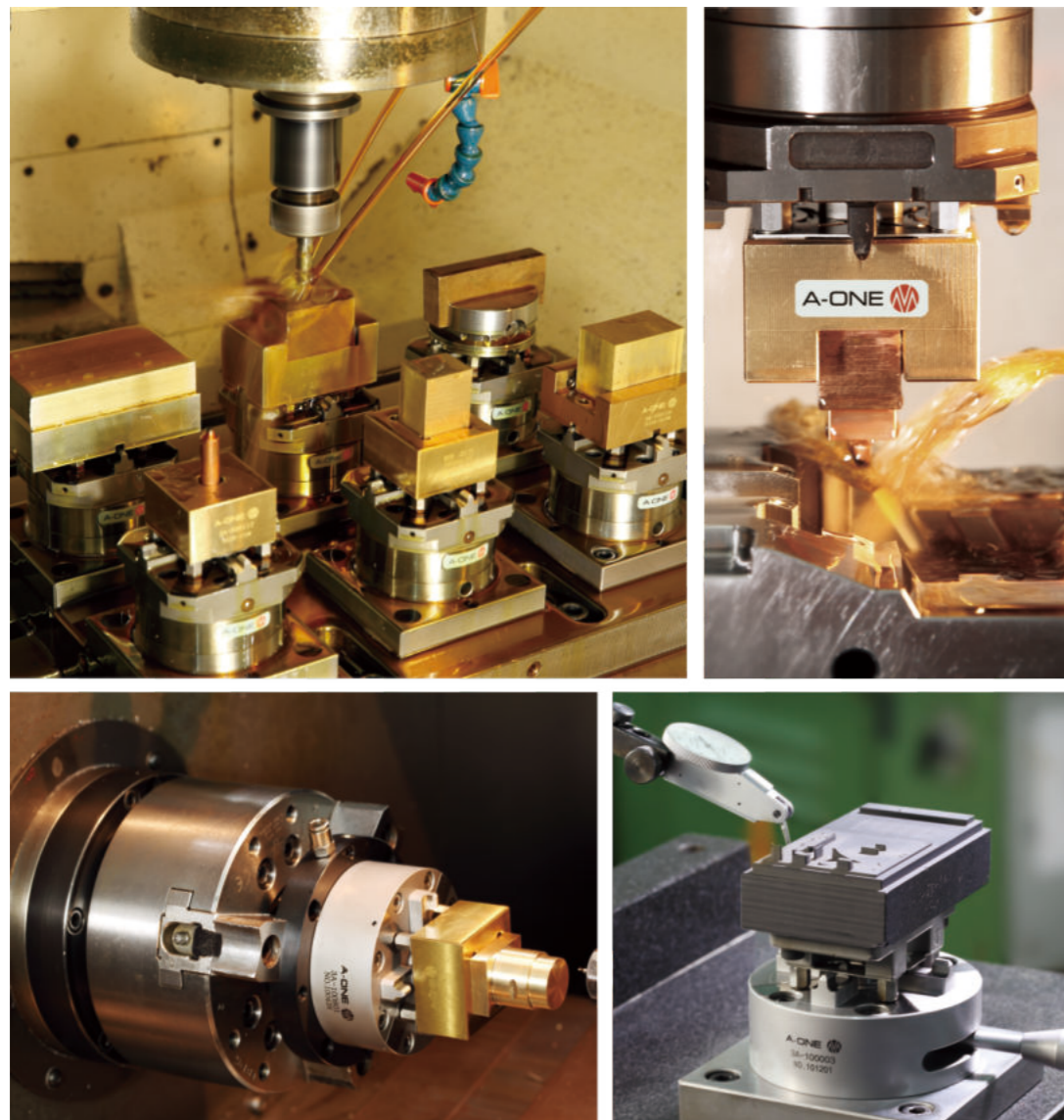

3A 产品应用于钢件加工

3A products used in steel workpieces processing

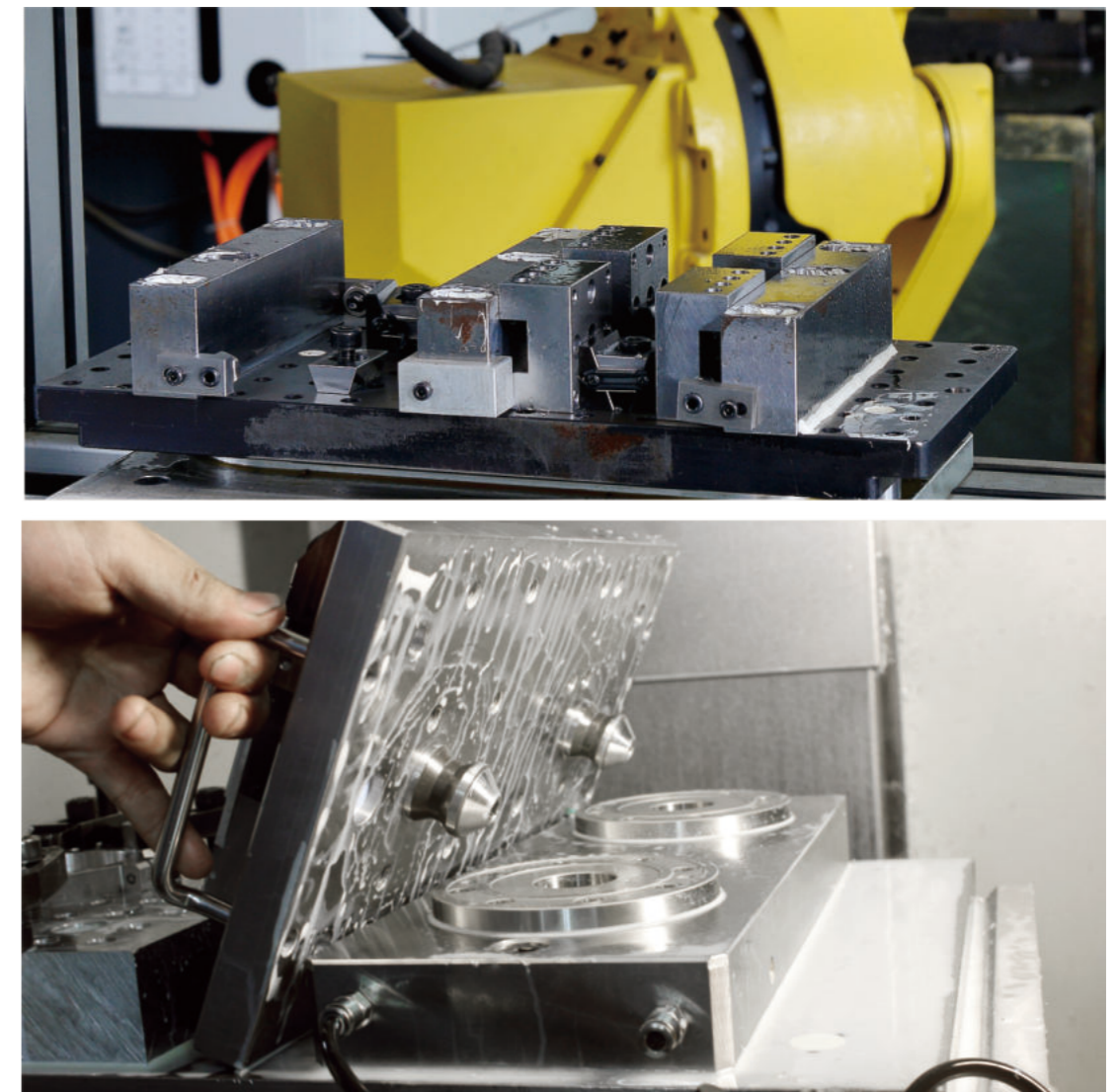

A-ONE工具系统用于四轴、五轴加工
A-ONE tooling system for four-axis, five-axis machining

燕尾槽夹具
Forked tail holder

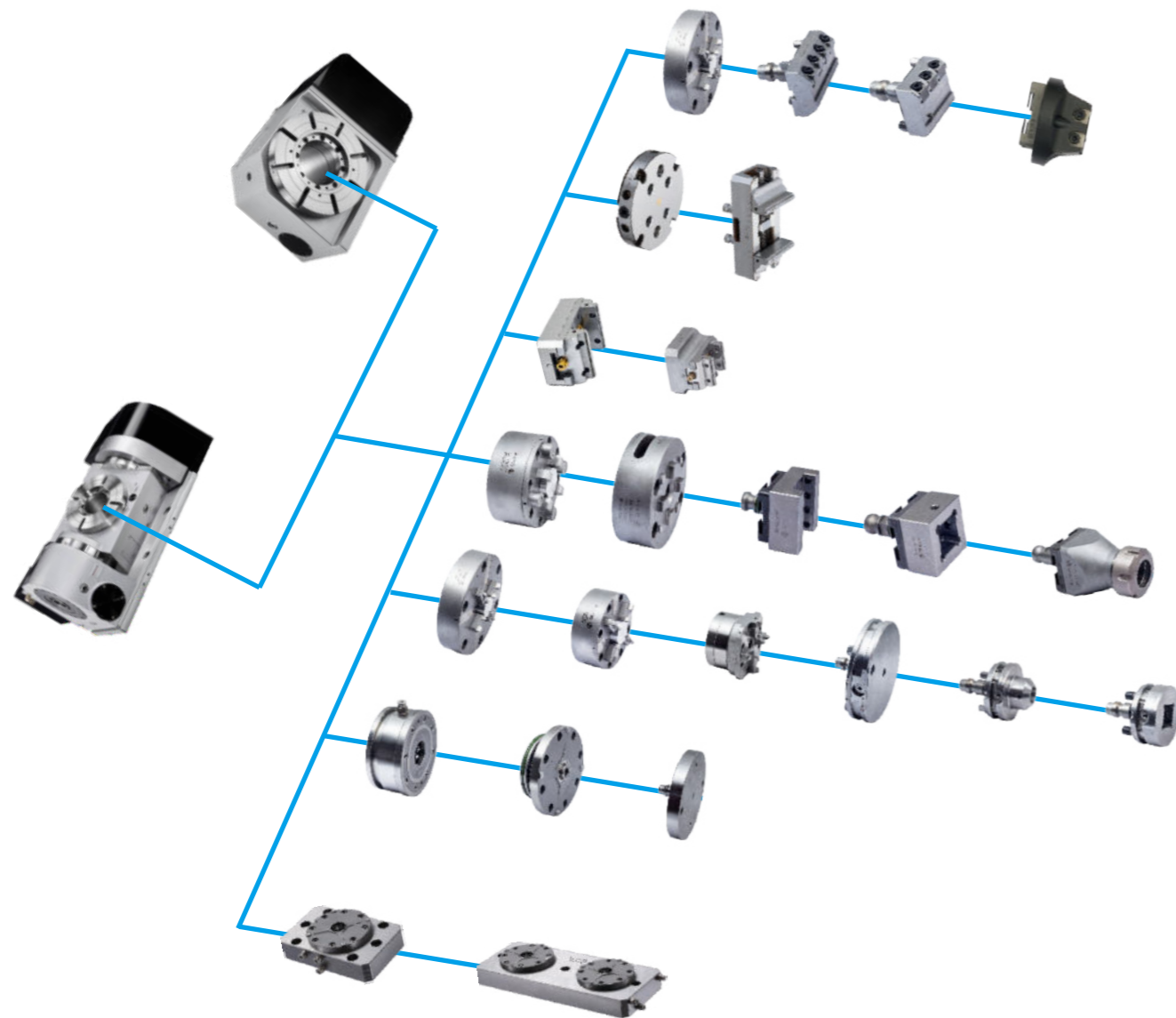

提供燕尾夹具个性化定制
 Offer customized dovetail clamp

- 燕尾夹具具有快速、稳定、夹紧力大、所需夹持位少等特点，一次装夹可实现五面加工。
 The dovetail clamp has the characteristics of fast, stable, large clamping force and less required clamping position, which can realize 5-axis machining per time.
- A-ONE燕尾夹具系列产品丰富，标配ITS接口、也可支持直接锁紧安装，提供定制服务，可按要求进行设计与制作。
 A-ONE dovetail clamps are available in a wide range of products, with standard ITS interfaces and direct locking installation. Customized services are available and can be designed and produced as required.



零点定位系统
Zero point system

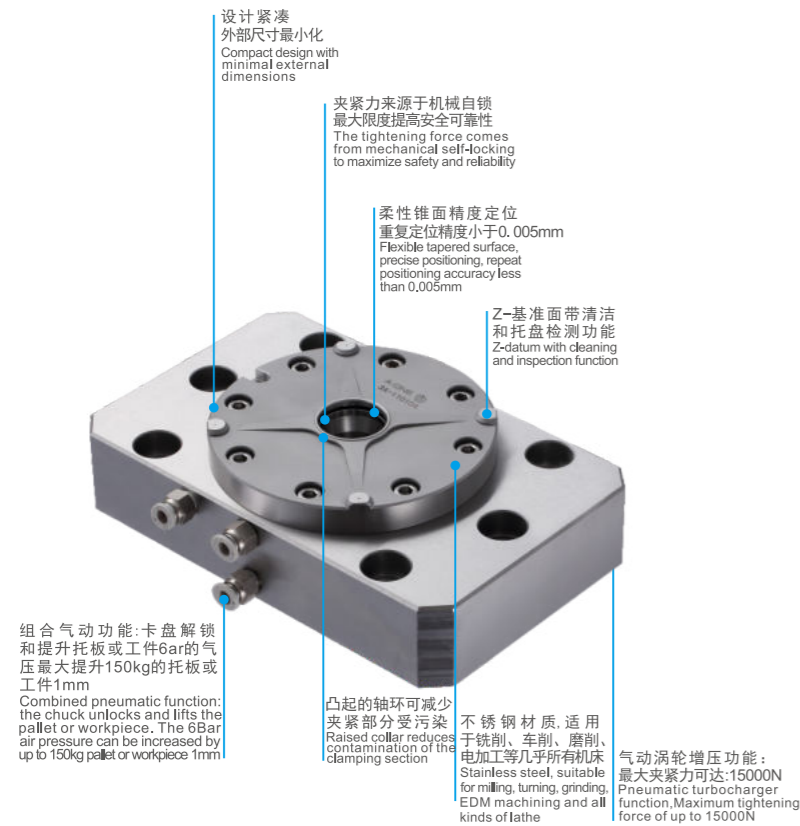

- 快速更换治具
Quick change fixture
- 快速更换产线
Quick change production line
- 重复定位精度 < 0.005mm
Repeat positioning accuracy < 0.005mm
- 降低生产成本
Reduce manufacturing cost
- 提高设备稼动率
Improve equipment utilization
- 整合产线模组化
Integrated production line modularization

传统调机
Traditional Tuning

调机所需2~4小时以上, 停机即是损失
It takes more than 2-4 hours to adjust the machine, and the downtime is a loss



停机更换工件/模治具
Stop replacing workpiece /mold



人工调机
Manual adjustment



校正基准原点 (坐标系)
Correction reference origin (coordinate system)



程式单节验证
Single-section program verification



进行生产
In production

3分钟完成定位
3 minutes to complete positioning



使用A-ONE零点定位夹持系统
Use A-one zero positioning clamping system



直接定位
Direct positioning

零点定位系统
Zero point system

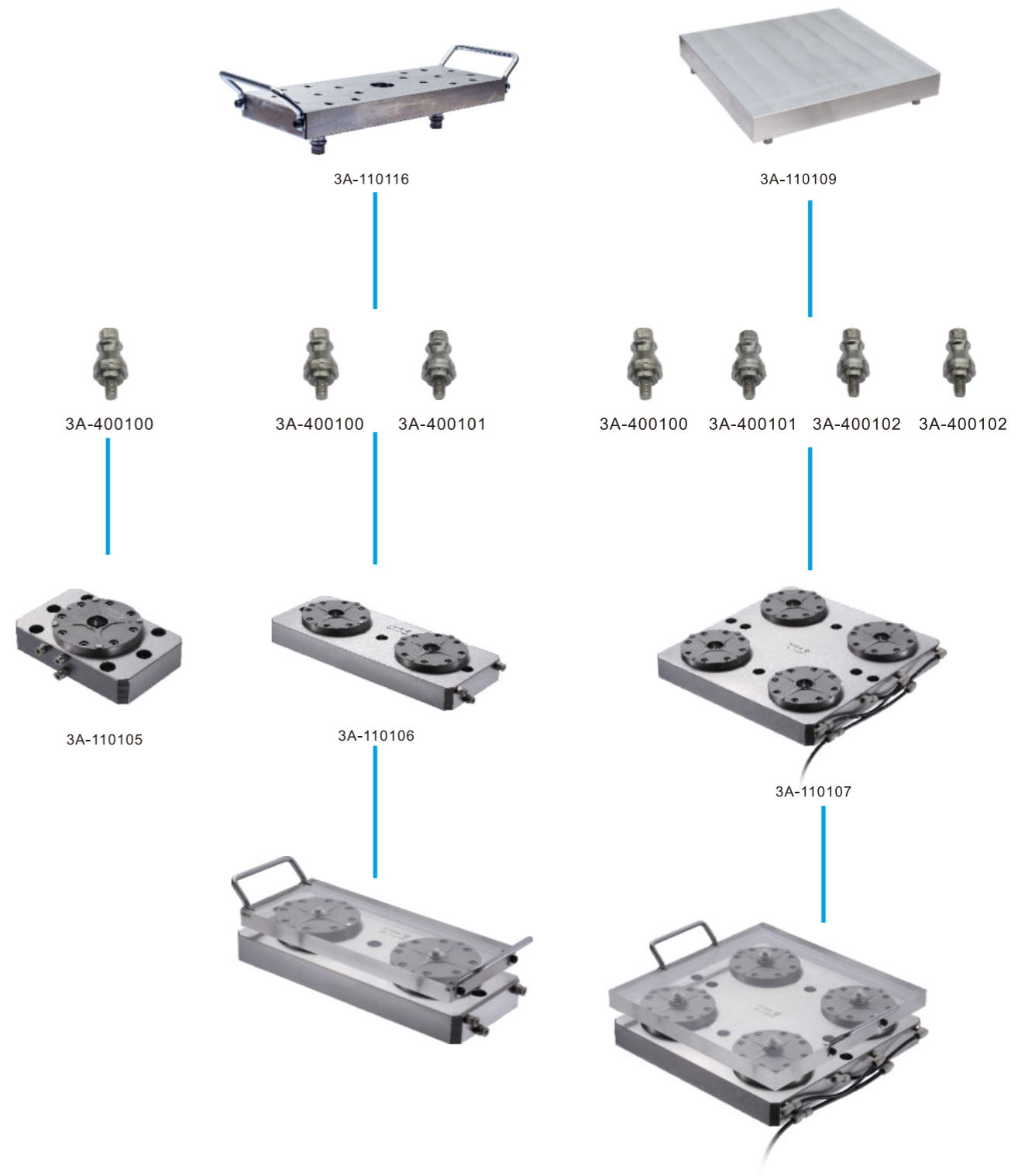

UPC系统
UPC System

强力卡盘
Power chuck

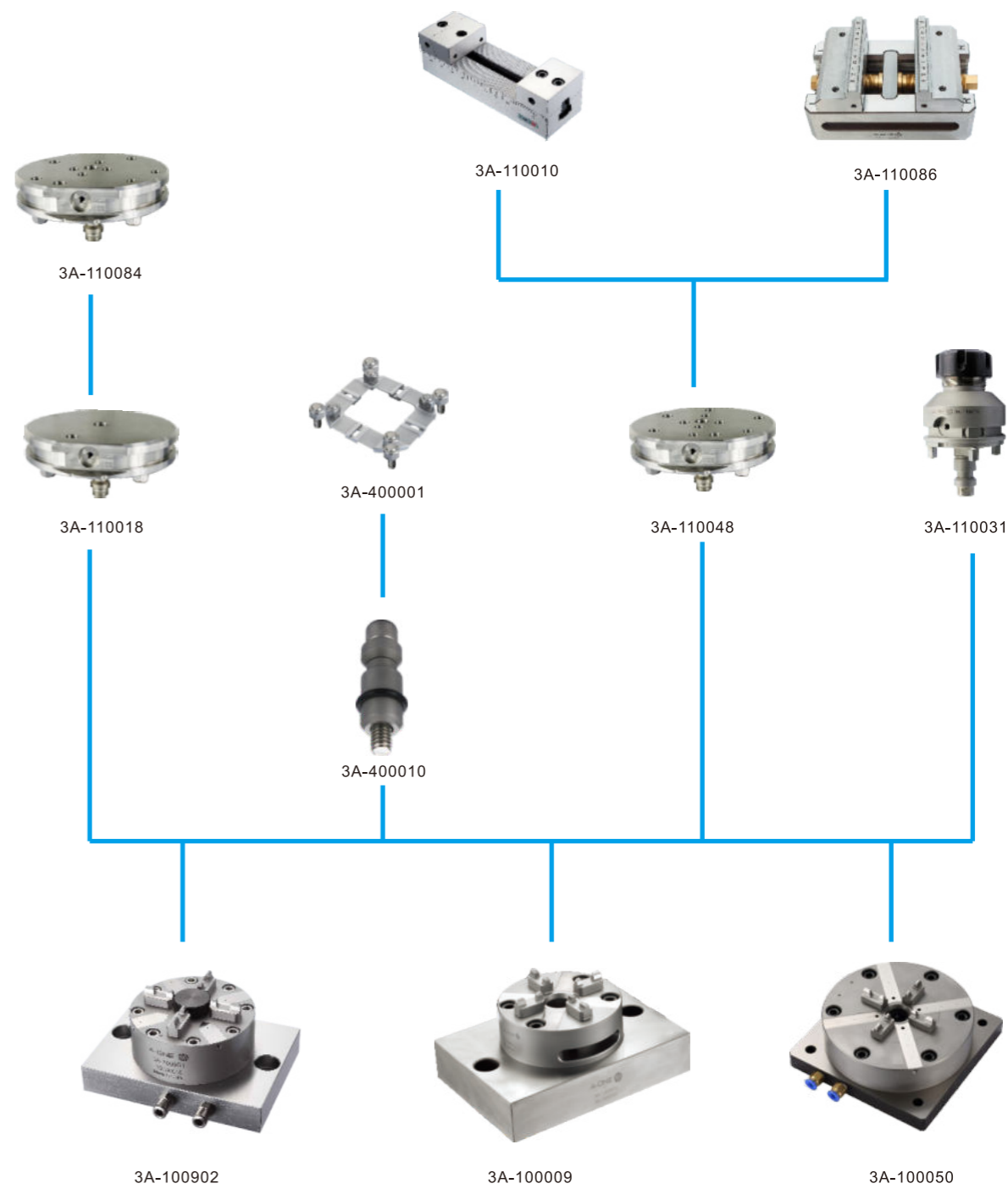
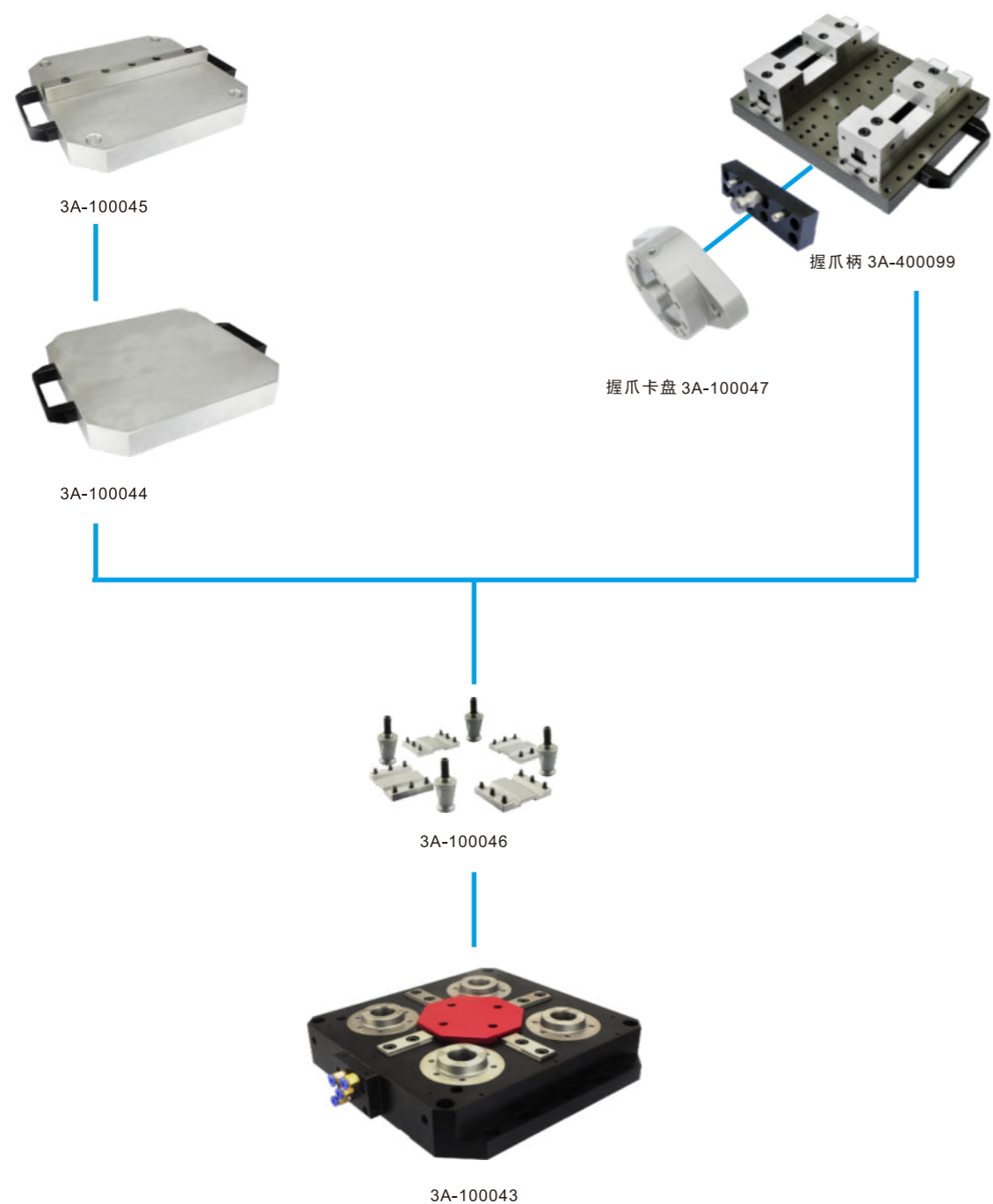

自定心虎钳 Self Centering Vise

五轴咬合式硬爪虎钳
Makro.Grip

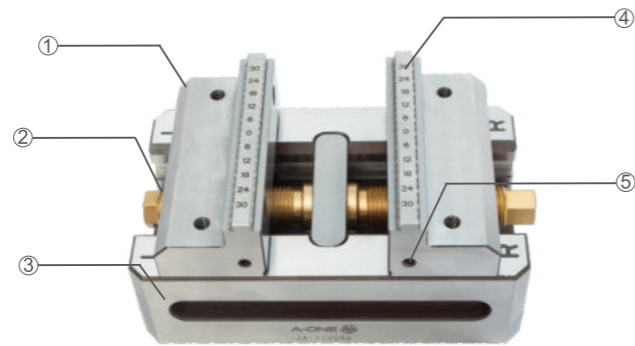

特点:

Characteristics:

1. 卡爪的光面可以用于无咬痕工件的夹持或已加工面的夹持;
The smooth surface of the jaws can be used for clamping of workpieces without biting or clamping of machined surfaces
2. 双导向长行程导轨, 丝杆螺母副驱动卡爪;
Double guide long stroke guide, screw nut vice drive jaw
3. 基体结构稳固, 经久耐用; 同时自重较轻, 方便手工上下料;
The base structure is stable and durable; at the same time, the weight is light, and it is convenient for manual loading and unloading.
4. 卡爪上端两面均带有咬齿, 能够在夹持3mm的高度上可靠夹紧工件;
The upper end of the claw has a tooth on both sides, which can reliably clamp the workpiece at a height of only 3mm
5. 预留螺纹底孔用于安装辅助定位装置; 可安装于A-ONE148托板或零点托板
Reserved threaded bottom hole for mounting auxiliary positioning device; can be mounted on A-ONE ø148 pallet zero or point pallet.

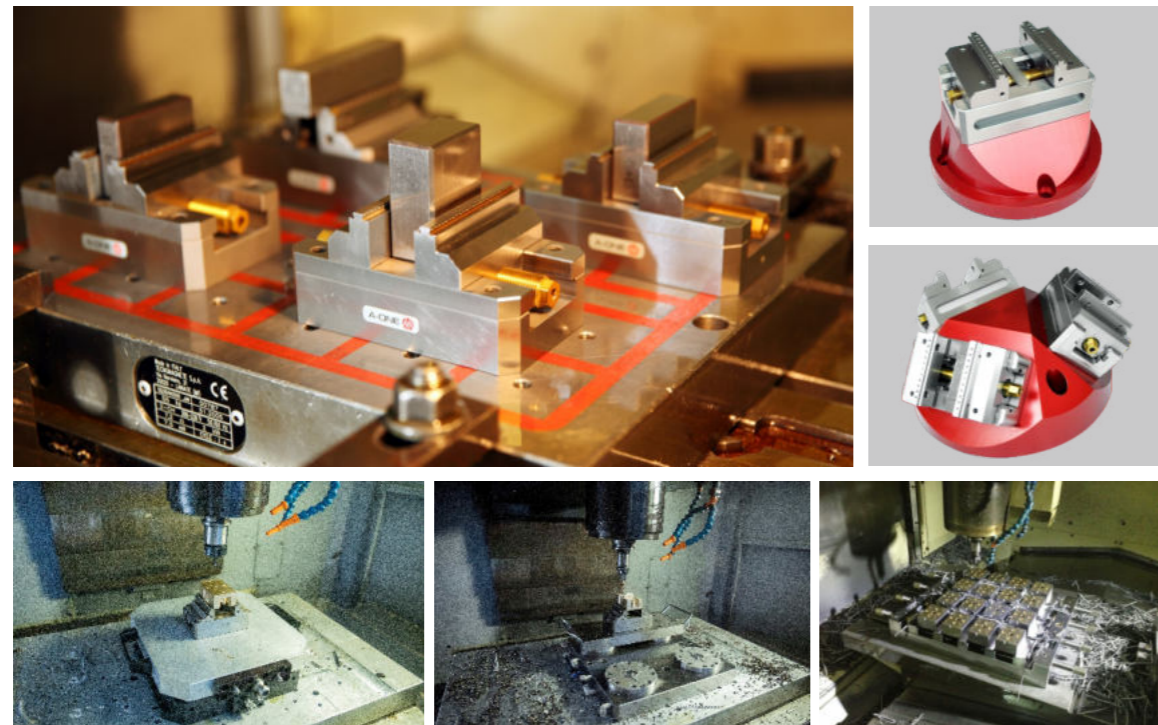

侧向膨胀器

Lateral expander

侧向膨胀器应用范例

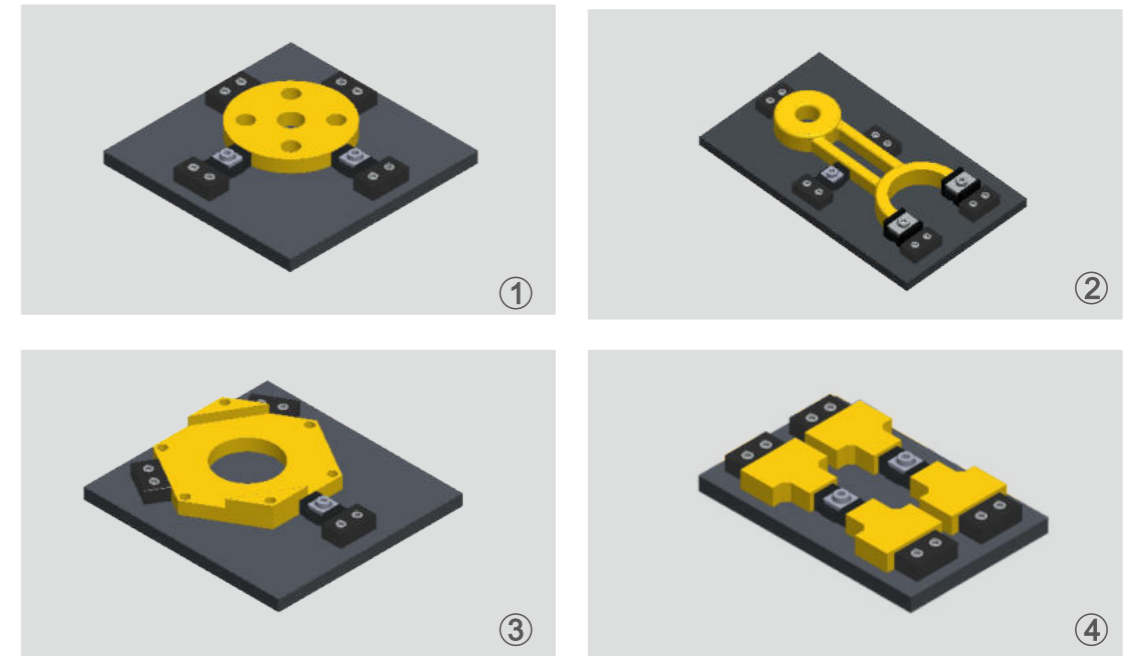

特点:

Characteristics:

1. 选用六角扳手轻松锁紧的设计结构
Easy to lock design structure with hex wrench
2. 迷你型虎钳具有更换工件及设置快速的特点, 可灵活运用因不同变化的设计需求
The mini vise has the characteristics of changing workpieces and setting up quickly, and can be flexibly applied to different design requirements.
3. 适用于不同工作平台 (三轴、四轴、五轴及卧式皆可使用)
Suitable for different kinds of machine table. (3-axis, 4-axis, 5-axis and horizontal can be used)

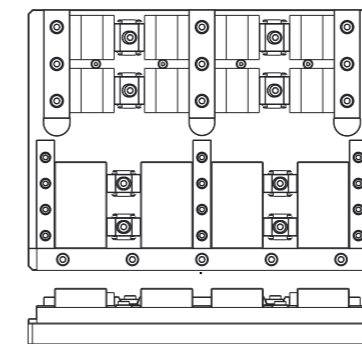

▶ 加工零件范例

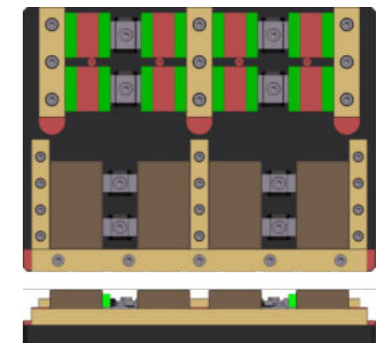

▶ 加工零件范例

基准卡盘及CNC夹具
Benchmark chuck and CNC jig

R型系列夹具
R Series fixture

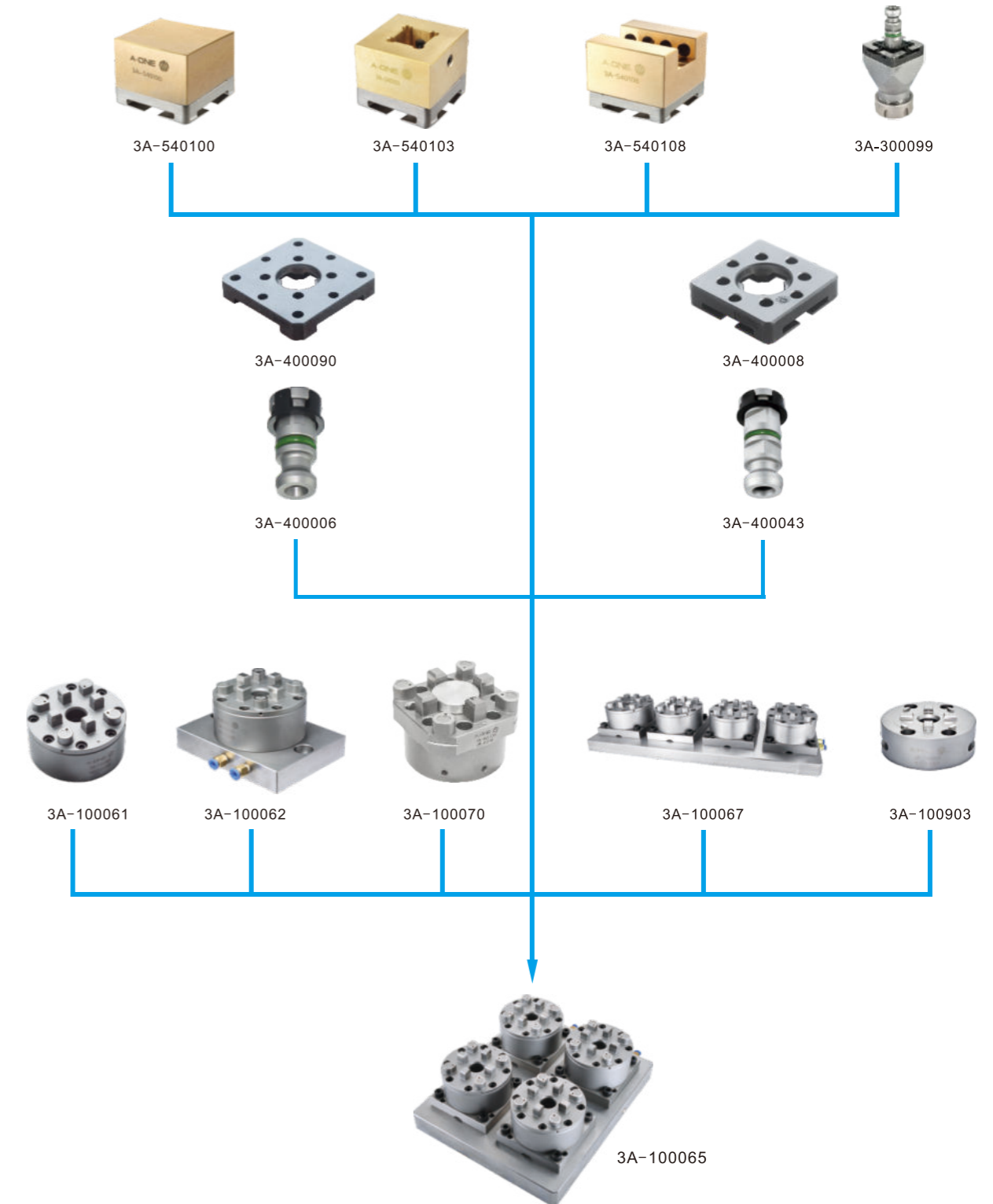
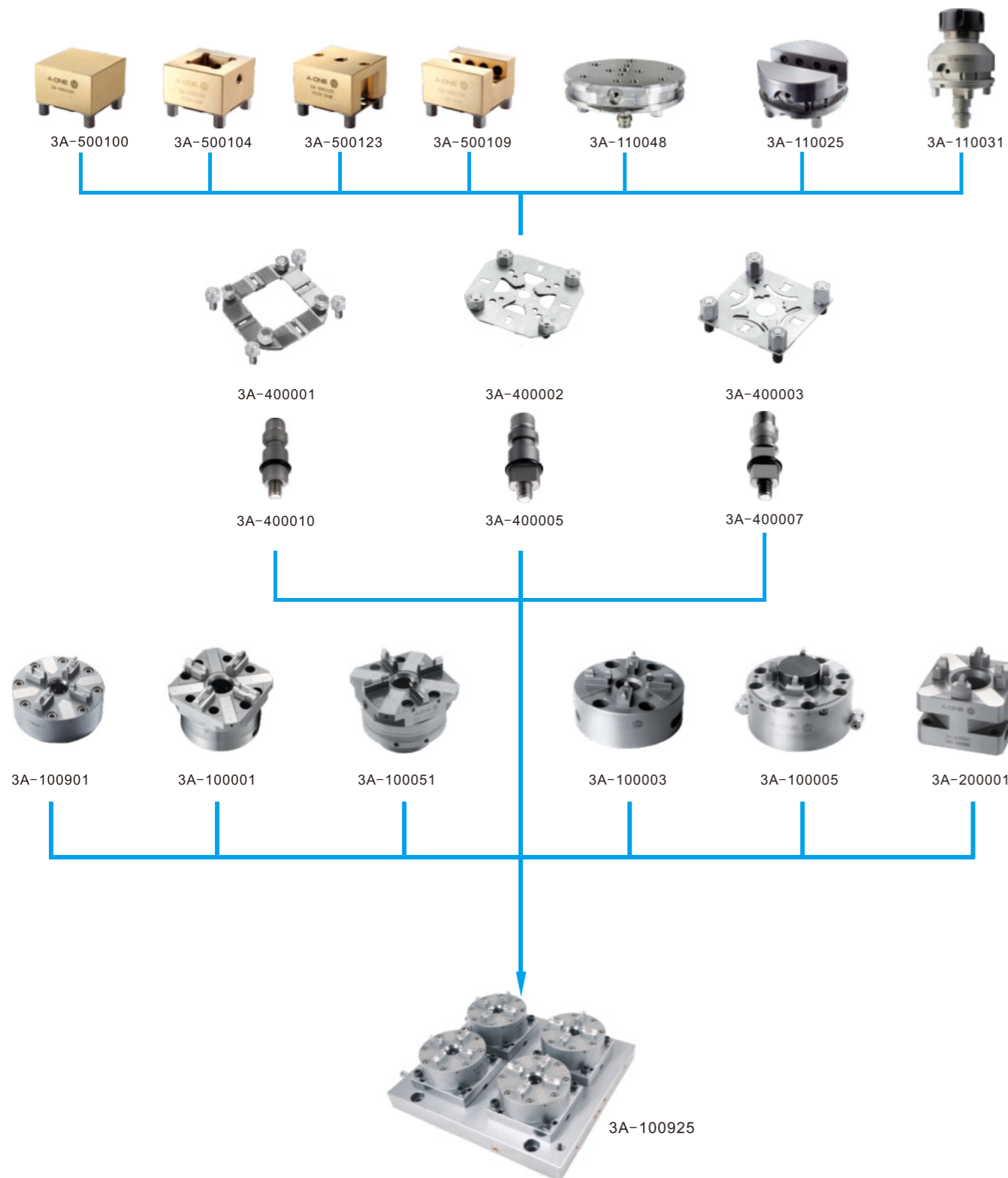

A-ONE 线切割夹具
A-ONE Wire EDM Tooling



A-ONE 线切割夹具
A-ONE Wire EDM Tooling

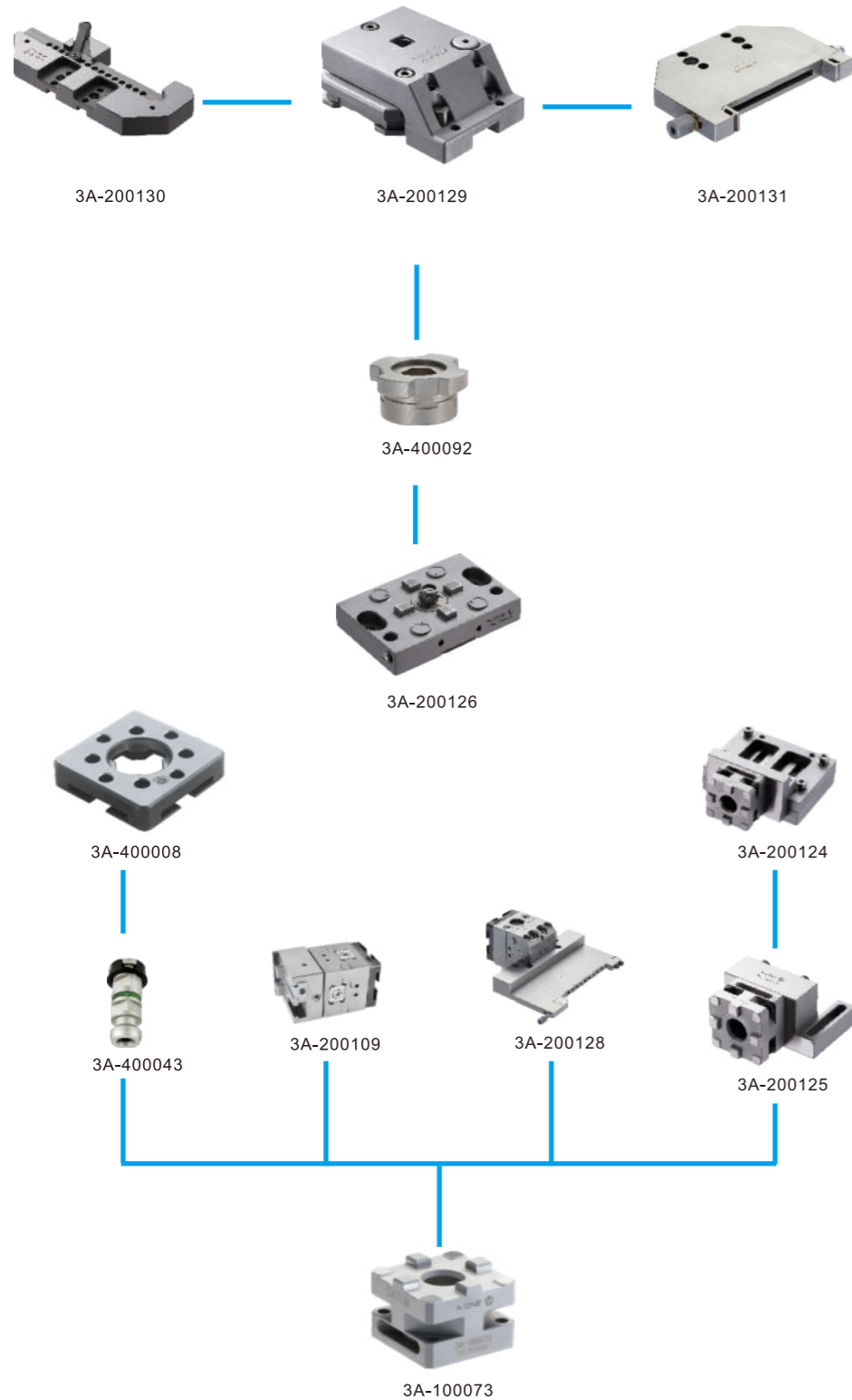

柔性生产线
Flexible production line

为您量身定制加工，检测等自动化一站式解决方案。
Customize processing, inspection and other automated one-stop solutions.

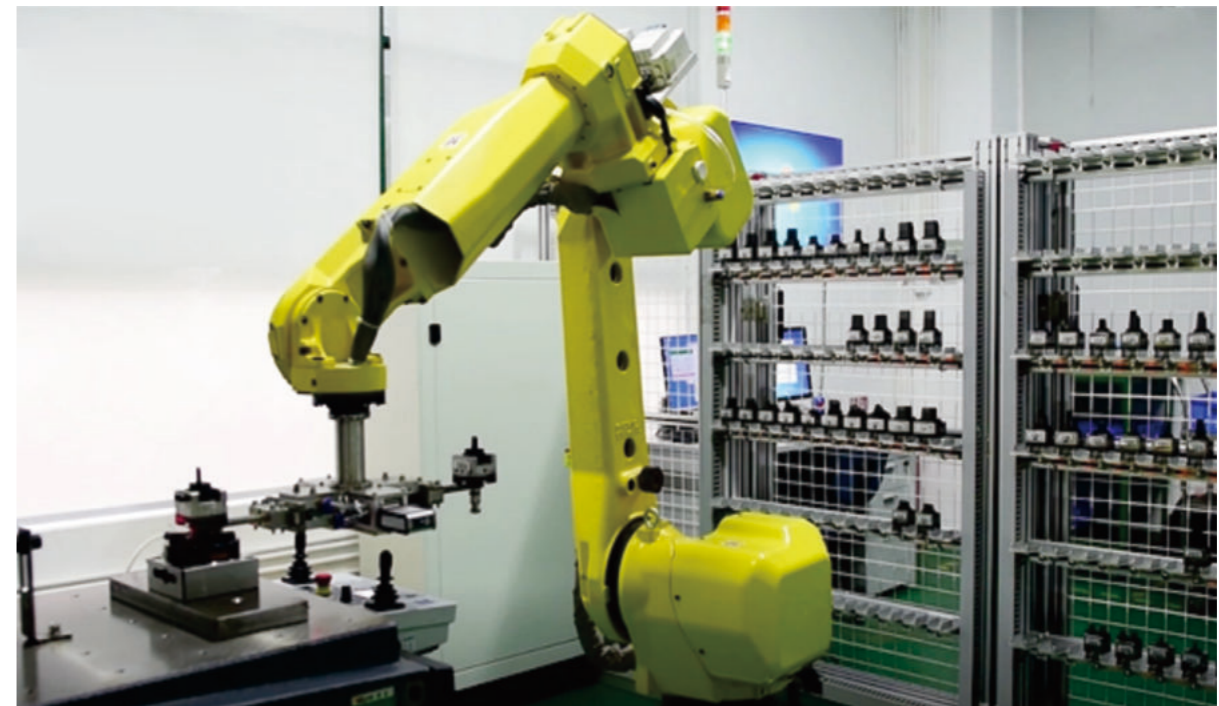

精钻服务
SERVICE NETWORK

快速响应售后服务
用心坚持专注品质
Quick response service
Insist on quality

一站式夹具 服务平台

3A夹具在标准化流程与自动化物理系统加工中有机结合, 为客户在铣床、磨床、钻床、电火花成型机床、线切割机床以及测量和预调台上的使用, 提供了重复定位精度2um的高精密夹具, 将生产工艺现场标准化, 并极大的提高设备使用率, 实现产出高效、制程精细。

Through the organic integration of standardized processes and automated physical systems to achieve high-efficiency output and fine processing, it is possible to bring 2um accuracy to customers through milling machines, grinders, drill presses, EDM machines, wire cutting machines, and measurement and presetting. The 3A fixture system is used on the stage, and we will gradually increase the effective use of production time.

24*365小时开通热线服务, 快速响应解决您的问题
Open hotline service 24*365 hours to respond quickly to solve your problem

根据客户实际需求, 可选择性提供免费样品试用
According to the actual needs of customers, we can provide free samples for testing

所有卡盘类产品免费保修一年
All chucks are free for one year warranty

专业的售后人员免费安装调试且对产品使用方法现场培训, 帮助您提高生产效率、延长3A产品使用寿命
Free installation and commissioning of professional after-sales engineer and on-site training on product usage methods to help you improve production efficiency and prolong the service life of 3A products

- 用于重型加工, 精密机械
 - 用于电火花成型, 线切割, 工模具制造
 - 零点快速定位系统
 - 非标夹治具订做
 - 模具、零件加工行业柔性自动化解决方案
 - T-ONE 钨钢夹头导套
- For heavy duty machining, precision machinery
 - For EDM shaping, WEDM, tool&die manufacturing
 - Zero point system
 - Customize of non-standard clamping holder and fixture
 - Mould / precision parts processing / flexible automation solution
 - T-ONE carbide collet chuck & guide bush

- ① 建立夹具售后服务档案 | Establishing a fixture service file
- ② 技术支持 | Technical Support
- ③ 服务、保修 | Service, warranty
- ④ 培训、维护 | Training and maintenance

部分合作伙伴 (排序不分先后)

Partial partner

模具加工 Mold processing

 宝利根	 宝田精工	 比亚迪	 常州华威模具	 大豪车业
 大连菱艺精密	 得意电子	 德丰电创	 东菱	 东泰精密
 凤铝	 富士康集团	 广东长盈	 赫比	 恒德
 宏丰	 金莱特	 金三维	 精英模具	 九江金鹭
 九牧厨卫	 莱克	 理光	 立讯精密工业	 领益
 绿点科技	 南平铝业	 宁波华德	 宁波继峰	 宁波均胜
 普联	 群创光电	 厦门华尔达	 山东豪迈	 上海瀚氏
 深圳凯中精密	 伟康医疗	 香港模具	 烟台霍富	 亿和
 银宝山新	 珠海格力大金	 珠海三威		

口碑好, 22 年经验积累

Good word of mouth, 22 years of experience

凭借品质稳定、性价比高, 得到海内外客户的高度肯定。

Thanks to its stable quality and high cost performance, it is highly recognized by customers at home and abroad.



零件加工 Parts processing

 ASM先进半导体	 TTI	 北方自动控制研究所	 彼联科技	 伯恩光学
 潮州三环	 大博医疗	 东莞祥鑫	 国泰达鸣精密	 杭州西子航空
 恒拓高	 华生电机	 利元亨	 牧野	 南京造币厂
 南兴木工	 锐健	 瑞声科技	 上海航天	 一汽大众
 中船重工	 中国工程物理研究院	 中均科技	 中山科瑞	

其他 Other

 北京精雕集团	 汉霸	 航天壹巨	 庆鸿机电	 沙迪克	 株洲科力特
---	---	---	---	--	--

销售网络
SALES NETWORK

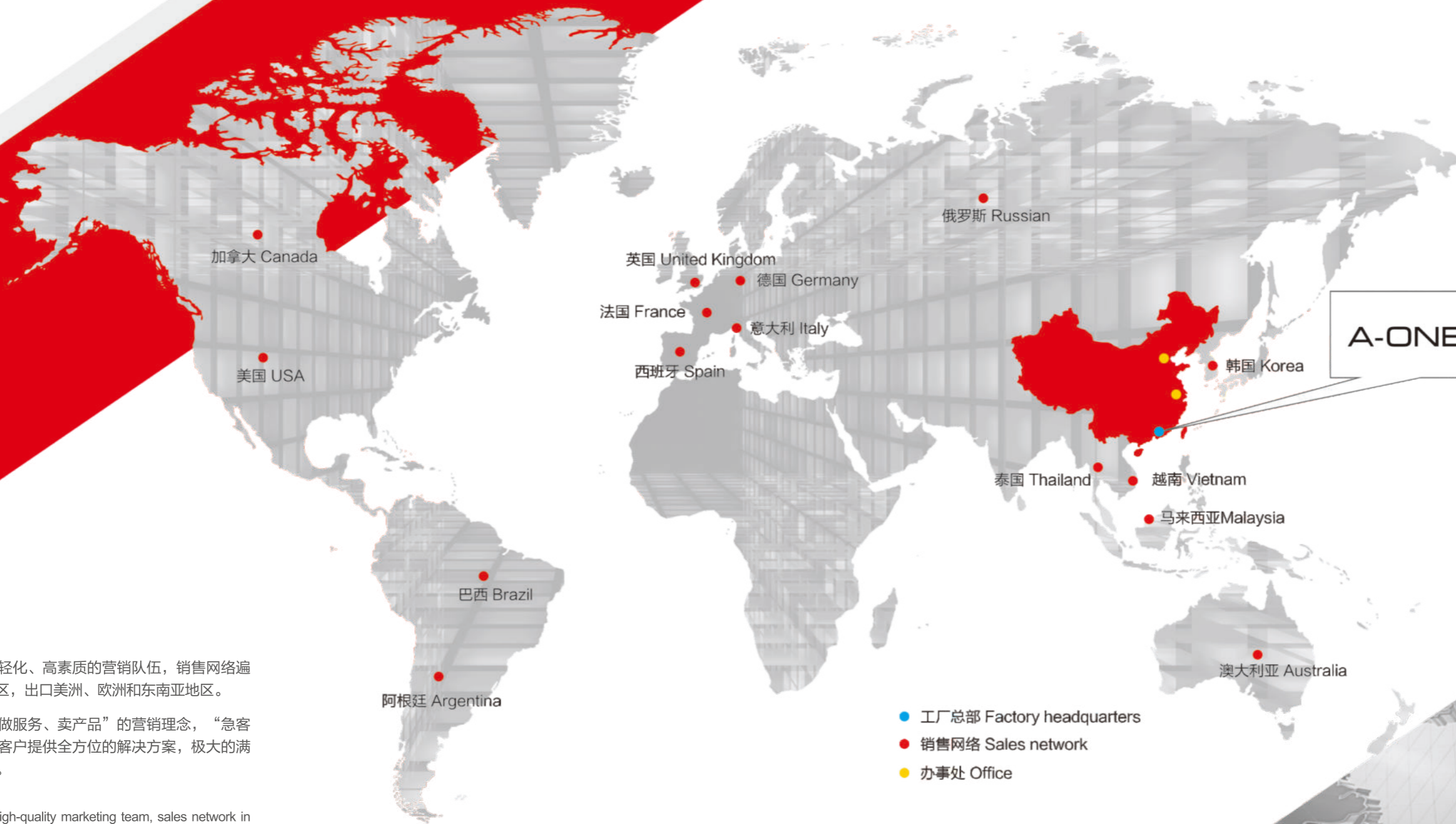

精钻拥有一支专业化、年轻化、高素质的营销队伍，销售网络遍布全国各大制造业密集地区，出口美洲、欧洲和东南亚地区。

本着“树品牌、建网点、做服务、卖产品”的营销理念，“急客户所急、想客户所想”为客户提供全方位的解决方案，极大的满足了广大客户的采购需求。

Has a professional, young, high-quality marketing team, sales network in major manufacturing areas throughout the country, exports to the Americas, Europe and Southeast Asia.

Based on the marketing concept of “tree branding, network establishment, service, and product sales”, “emergency customers and customers want” to provide customers with a full range of solutions, which greatly satisfy the majority of customers purchasing needs.